

SKID DETAIL

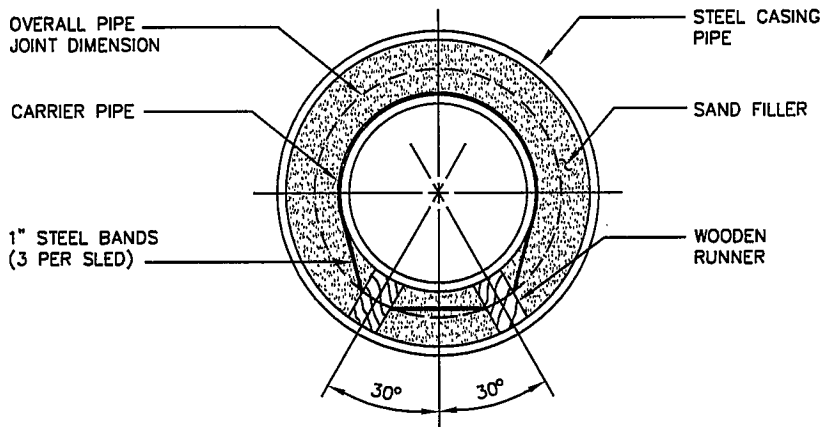

PIPE CASING DETAIL

CARRIER PIPE NOMINAL DIA.	CASING PIPE		RUNNER SIZE
	MIN. O.D.	MIN. WALL THICK.	
4"	12"	0.375 - 0.5	2" x 4"
6"	16"	0.375 - 0.5	2" x 4"
8"	18"	0.375 - 0.5	2" x 4"
12"	22"	0.375 - 0.5	2" x 4"
16"	28"	0.5 - 0.625	2" x 6"
20"	32"	0.5 - 0.625	2" x 6"
21"	34"	0.5 - 0.625	2" x 6"
22"	36"	0.625 - 0.75	2" x 6"

LESSER MIN. WALL THICKNESS BASED ON 1:4 GROUT. GREATER THICKNESS INDICATED REQUIRED FOR SAND FILLER.

REVISED 10-08-03 CADD DRAWING BY GTS CONSULTANTS, INC.

DATE: JAN. 1991

DRAWN: G.G.&J.T.R.

SCALE: NONE

LAKWOOD TOWNSHIP
MUNICIPAL UTILITIES AUTHORITY

PIPE CASING DETAIL 31