

PIPE SIZE	ROD DIA.	CLAMP DIMENSIONS (INCHES)									
		D	B	C	D	E	F	G	H	I	J
6"	3/4"	7-1/16	1/2	1/2x3-1/2	2	.75	.660	3.1	1.13	10.64	18.34
8"	3/4"	9-3/16	1/2	1/2x3-1/2	2	.75	.660	3.1	1.13	12.78	20.48
10"	3/4"	11-3/8	1/2	1/2x3-1/2	2	.75	.660	3.1	1.13	14.96	22.66
12"	3/4"	13-1/2	1/2	1/2x3-1/2	2	.75	.660	3.1	1.13	17.08	24.78
16"	1"	17-7/8	3/4"	5/8x4-1/2	4	.938	.780	4.14	1.69	22.80	32.96
18"	1"	20	3/4"	3/4x5	4	1.125	.950	4.14	1.69	25.28	35.81
20"	1"	22-1/8	3/4"	3/4x5	4	1.125	.950	4.14	1.69	27.40	37.93
24"	1-1/4"	26-3/8	3/4"	3/4x5-1/2	5	1.125	.950	5.18	1.69	31.66	42.19

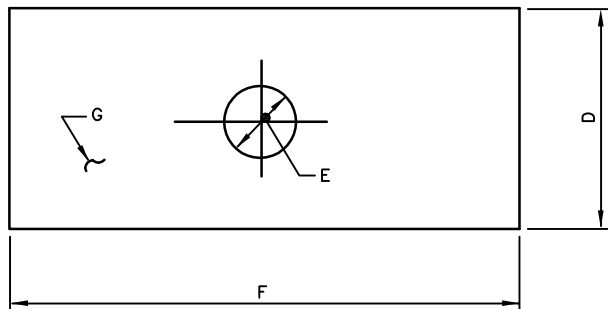

WASHERS			
D	E	F	G
WIDTH	HOLE DIAMETER	LENGTH	THICKNESS
3"	7/8"	6"	3/8"
3"	1 1/8"	7"	1/2"
4"	1 3/8"	7"	5/8"

REVISED 10-08-03 CADD DRAWING BY GTS CONSULTANTS, INC.

DATE: JAN. 1991

DRAWN: G.G.&J.T.R.

SCALE: NONE

LAKWOOD TOWNSHIP
MUNICIPAL UTILITIES AUTHORITY

TIE ROD CLAMP

6